

1/2" HEAVY DUTY REVERSIBLE AIR DRILL

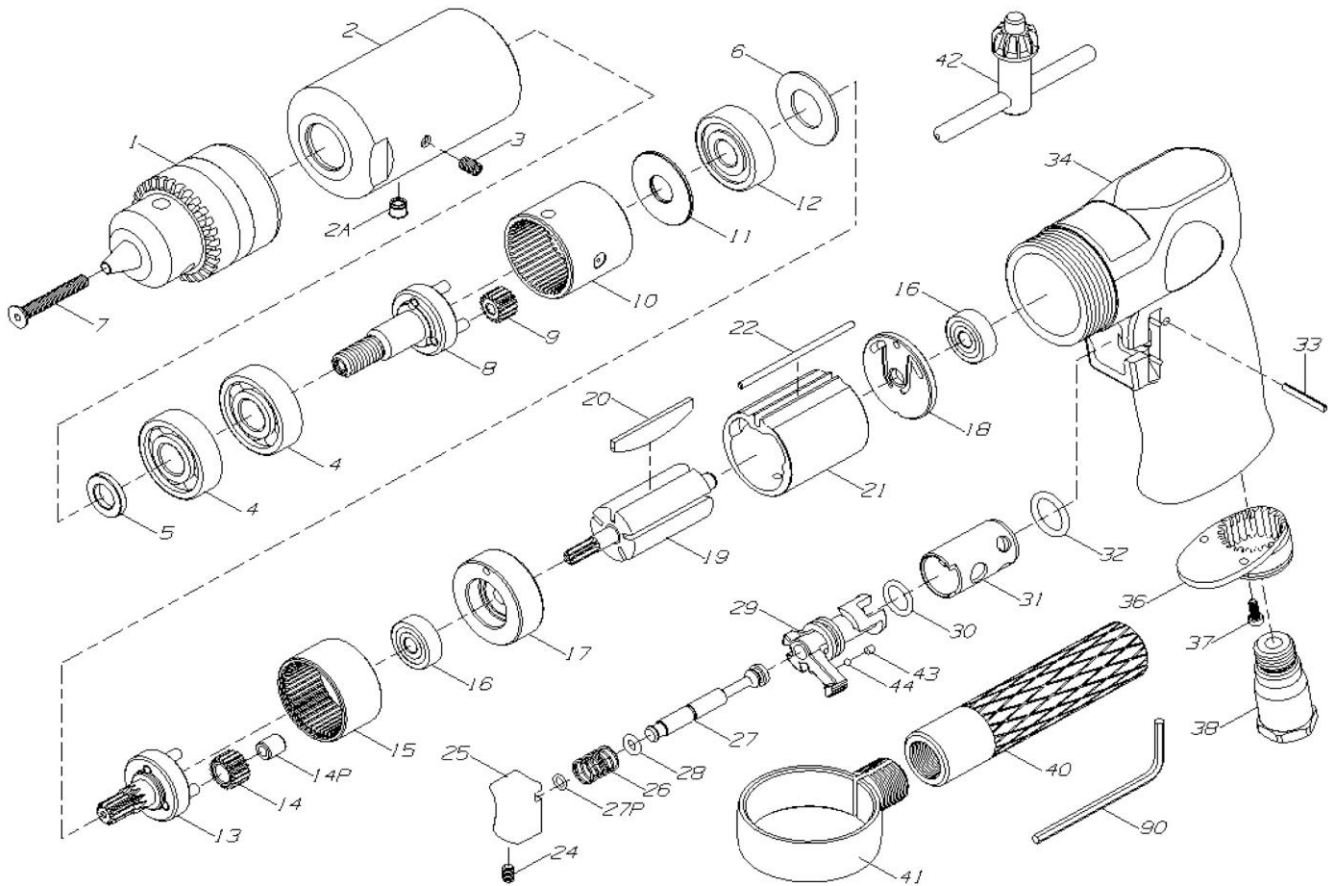

5406

INDEX NO.	DESCRIPTION	REQ'D NO.	INDEX NO.	DESCRIPTION	REQ'D NO.
01	1/2" Chuck	1	22	Motor Pin	1
	1/2" Keyless Chuck		24	Set Screw	1
02	Clamp Nut	1	25	Trigger	1
02A	Ball Cap	1	26	Spring	1
03	Set Screw	1	27	Throttle Valve	1
04	Ball Bearing	2	27P	O-Ring	1
05	Washer	1	28	O-Ring	1
06	Washer	1	29	Reverse Valve	1
07	Screw	1	30	O-Ring	1
08	Planet Carrier	1	31	Reverse Valve Block	1
09	Planet Gear	3	32	O-Ring	1
10	Internal Gear	1	33	Pin	1
11	Spacer	1	34	Housing	1
12	Ball Bearing	1	34P	Housing Sleeve(Optional)	1
13	Planet Carrier	1	36	Deflector	1
14	Planet Gear	3	37	Screw	2
14P	Bushing	3	38	Inlet Bushing	1
15	Internal Gear	1	40	Handle	1
16	Ball Bearing	2	41	Clamp Ring	1
17	Bearing Case	1	42	1/2" Chuck Key	1
18	Rear End Plate	1	43	Rubber	1
19	Rotor	1	44	Steel Ball	1
20	Rotor Blade	5	90	Allen Wrench	1
21	Cylinder	1			

0000.00.00

2012.11.27 2015.03.26